

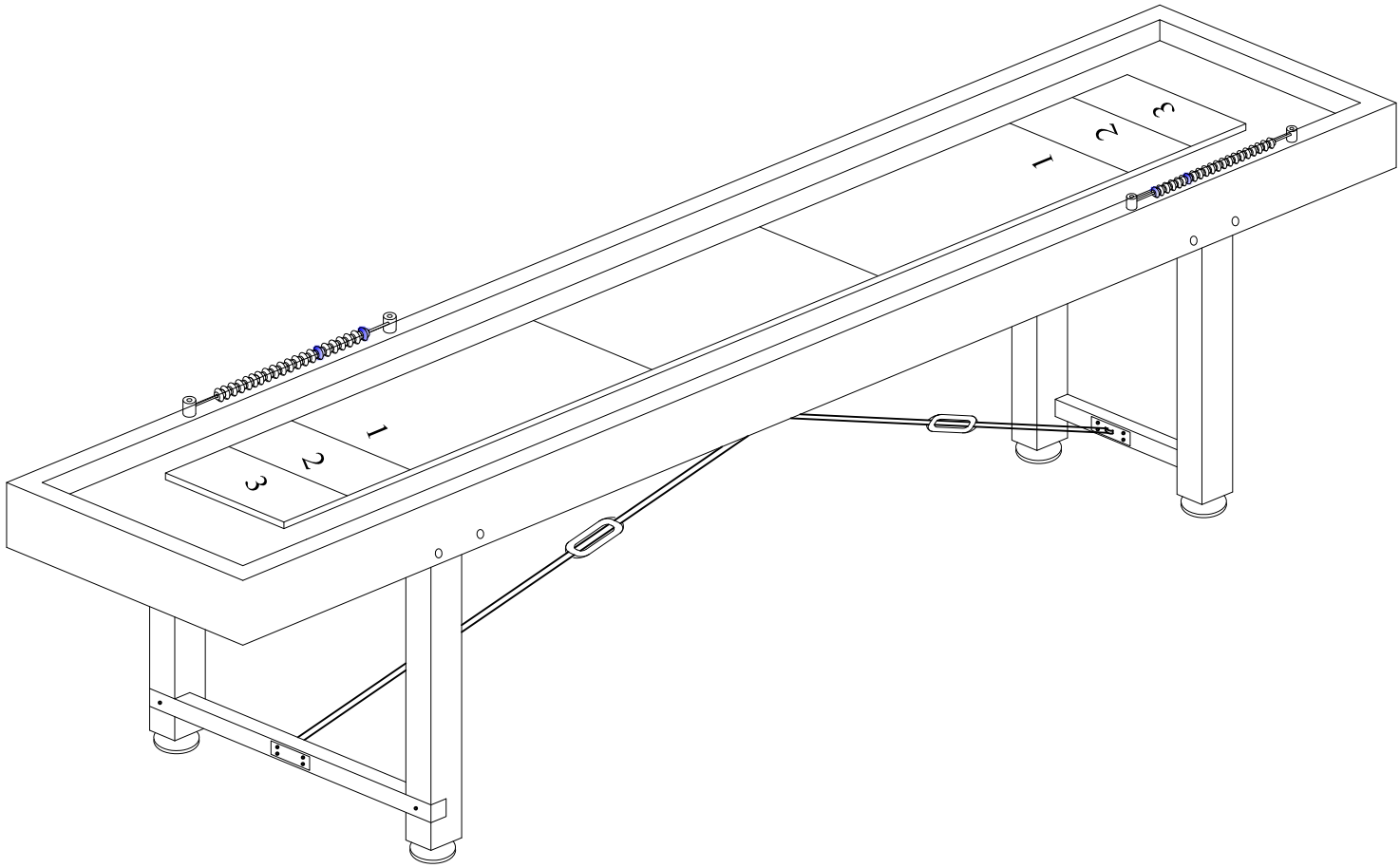

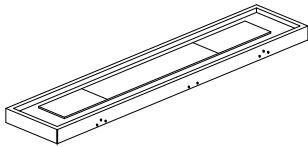

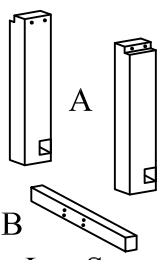

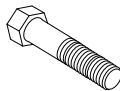



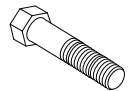

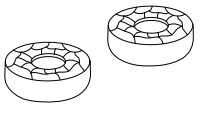
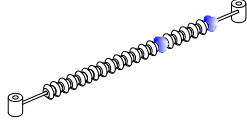
# INSTRUCTION MANUAL

## FOR SHUFFLEBOARD

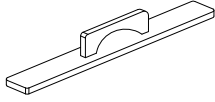
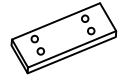

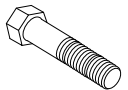
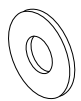
# ASSEMBLY INSTRUCTION

<p>#1</p>  <p>Cradle 1 pcs</p>	<p>#2</p>  <p>Leg Set 2 sets</p>	<p>#3</p>  <p>1/4"*3/4" Bolt 8 pcs</p>	<p>#4</p>  <p>Leg Leveler 4 pcs</p>	<p>#5</p>  <p>1/4"*3" Bolt 12 pcs</p>
<p>#6</p>  <p>1/4"*19mm Washer 28 pcs</p>	<p>#7</p>  <p>Red and blue puck each 4 pcs</p>	<p>#8</p>  <p>Wooden Slide scorer 2 set</p>	<p>#9</p>  <p>Screw F4*1-1/2" 4 pcs</p>	<p>#10</p>  <p>1/4Nut 8 pcs</p>
<p>#11</p>  <p>Wood cap 4 pcs</p>	<p>#12</p>  <p>Turn Buckle Set 2 set</p>	<p>#13</p>  <p>Wiper 1 pcs</p>	<p>#14</p>  <p>Metal Plate 2 pcs</p>	<p>#15</p>  <p>Wrench 1 pcs</p>
<p>#16</p>  <p>5/16"*4" Bolt 8 pcs</p>	<p>#17</p>  <p>5/16"*23mm Washer 8 pcs</p>	<p>#18</p>  <p>1/4Wrench 1 pcs</p>		

# ASSEMBLY INSTRUCTION

## Step 1: Assembly of Legs

\*Use blot(#16) and washer(#17) to fix leg posts(the part#A of #2 leg set) to cradle(#1), then install leg levelers(#4) on leg posts.

\*Use blot(#5) and washer(#6) to fix one of the 2 leg cross bars (the part#B of #2 leg set) to a pair of leg post, then fix the other one the same way.

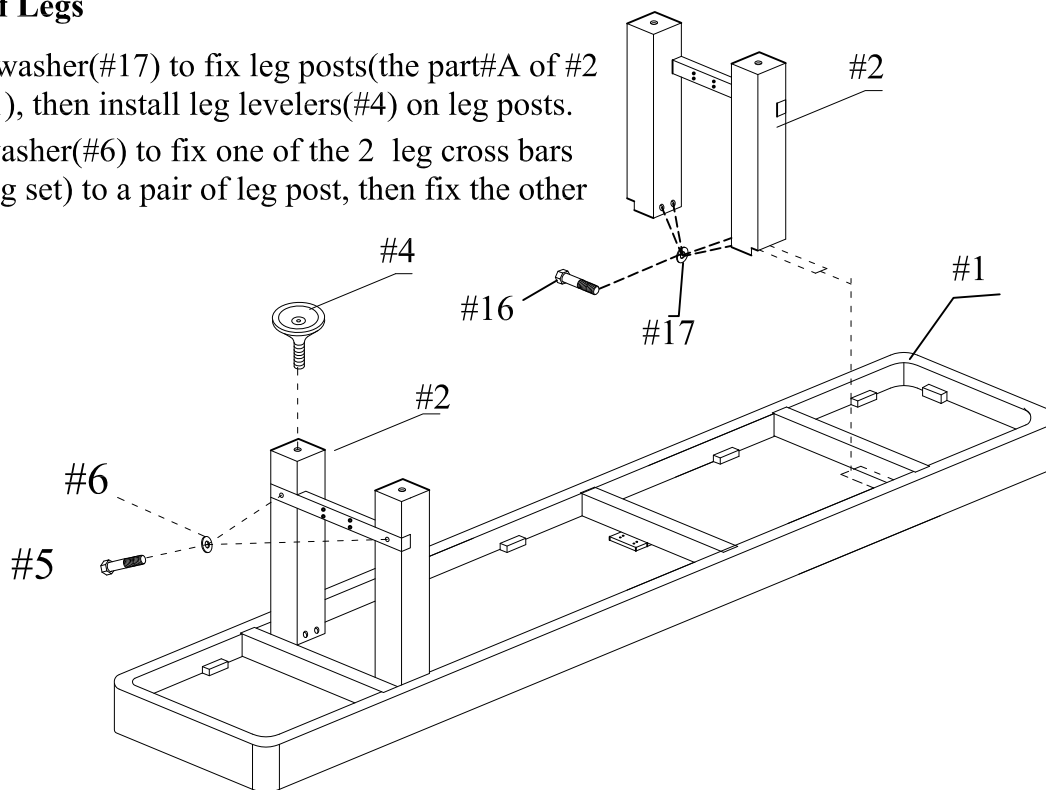

Step 2: Turn the table right side up, use screw(#9) to fix wooden slide scorer(#8) to top of side wall of cradle (#1), then put on wood cap(#11) to hide the screws.

Step 3: Fix the Turn Buckle Set(#12) on the cradle with bolt(#3), bolt(#5), washer(#6), nut(#10) and metal plate (#14). Note: Please adjust to turn the turn buckle set looser so as to have enough room to fix them on the table if necessary, then screw and turn the buckle set tight after assembly finished.

